

EPS40-1 y EPS40-2 Interruptores de Supervisión

Models Available

EPS40-1	Low Pressure Supervisory Switch
EPS40-2	High/Low Pressure Supervisory Switches
EPSA40-1	ULC/Canadian Version
EPSA40-2	ULC/Canadian Version

Replacement Parts

S07-66-XX	Replacement Cover Screws
WFDW	Replacement Cover Wrench
546-8000	Cover Tamper Switch



Pressure Adjustment Wheel



Product Overview

Sensitivity adjustment wheel, no special tools required

Reinforced diaphragm resists pressure spikes

Two conduit entrances provided

NEMA 4 rated

System Sensor EPS40 Series switches are designed for use in dry pipe systems or pres - sure tanks and water pressure supplies of automatic water control valves. The EPS40-1 has a single SPDT switch while the EPS40-2 model contains two SPDT switches.

The EPS40 Series features field adjustable pressure sensitivity to provide an alarm response between 10 and 100 psi. All models are factory set for use in a nominal 40 psi system. The EPS40-1 is factory set to respond at 30 psi at decreasing pres - sure while the EPS40-2 is factory set to respond at 50 psi on rising pressure and 30 psi at decreasing pressure. The pressure adjustment wheel requires no special tools and does not affect switch synchronization on the EPS40-2.

Engineering Specifications EPS40-1 (SPDT), EPS40-2 (2/SPDT)

Model shall be an EPS40-1 or EPS40-2 pressure type waterflow switch as manufactured by System Sensor of St. Charles, IL. They shall be installed on the sprinkler system with connection as shown on the drawings and/or as specified herein. Pressure switches shall be of the bellows-activated type.

Switches shall have a maximum service pressure rating of 250 psi and shall be adjustable from 10 - 100 psi. There shall be one (1) or two (2) SPDT contacts rated at 10.0 Amp @ 125/250 VAC and 2.5 Amp @ 6/12/24 VDC.

The contractor shall furnish and install, where indicated on the plans, pressure switches according to appropriate NFPA standards. Switches shall be provided with a 1/2" NPT male pressure connection to be connected into the air supply line on the system side of any shut-off valve. Switches shall provide 1 knockout type and 1 open hole for 1/2" conduit fitting attachment and a ground screw provision for electrical grounding.

The switch enclosure shall be weatherproof and carry a UL 4x/NEMA 4 rating when used with proper electrical fittings and conduit. The cover shall incorporate tamper-resistant screws.

The unit shall be listed by Underwriters Laboratories, Inc., the California State Fire Marshal, MEA, CSFM, LPCB, VdS and approved by Factory Mutual.



Specifications

Maximum Operating Pressure

250 psi

Differential

Approximately 3 psi @ 10 psi, 6 psi @ 100 psi

Maximum Adjustment Pressure Range

10 to 100 psi

Factory Setting

EPS40-1 operates at decreasing pressure at 30 psi
EPS40-2 operates at increasing pressure at 50 psi
and decreasing pressure at 30 psi

Pressure Connection

1/2" NPT male

Switch Contact Ratings

EPS40-1: One set SPDT (Form C)
EPS40-2: Two sets SPDT (Form C)
10.0 A, 1/2 HP @ 125/250 VAC
2.5 A @ 6/12/24 VDC

Dimensions

5.12" H x 3.325" W x 4.250" L
(13.0 cm x 8.4 cm x 10.8 cm)

Operating Temperature Range:

Indoor or outdoor use
-40°F to 160°F (-40°C to 71°C)

Cover Tamper Switch

UL Models: Optional P/N 546-8000
ULC Models: Factory Installed

Enclosure

Rated UL 4x, NEMA 4 for indoor or outdoor use

Shipping Weight

1.2 lbs. (.54 Kg)

Service Use

Automatic Sprinkler: NFPA 13
One or Two Family Dwelling: NFPA 13D
Residential Occupancies up to 4 Stories: NFPA 13R
National Fire Alarm Code: NFPA 72

Warranty

3 years

Pressure Switch Basic Dimensions

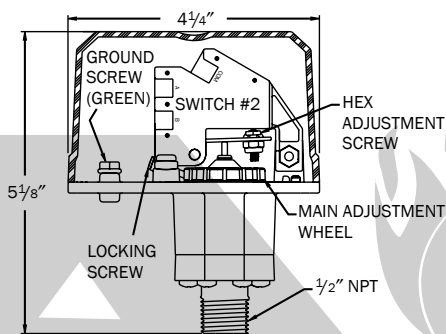

Electrical Connections for EPS40-1 and EPS40-2

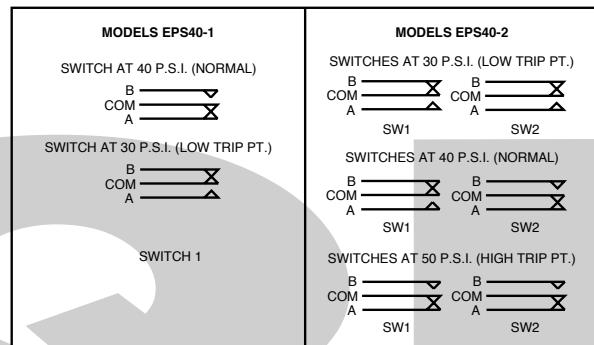

Typical Sprinkler Applications

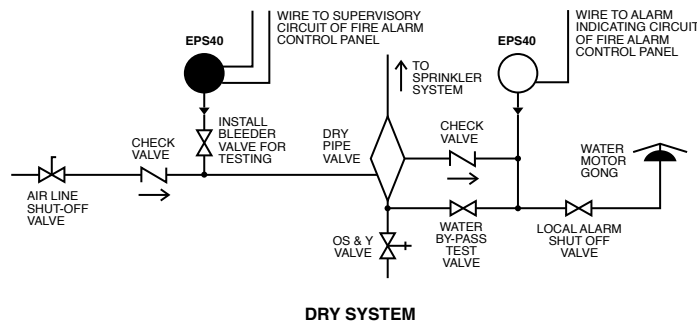

Ordering Information

Model	Description
EPS40-1	Low Pressure Supervisory Switch, One SPDT, 10-100 PSI
EPS40-2	High/Low Pressure Supervisory Switch, Two SPDT, 10-100 PSI
EPSA40-1	Low Pressure Supervisory Switch, One SPDT, 10-100 PSI (ULC Model)
EPSA40-2	High/Low Pressure Supervisory Switch, Two SPDT, 10-100 PSI (ULC Model)

Replacement Parts

Model	Description
S07-66-XX	Replacement Tamper Screws for Cover of EPS
WFDW	Replacement Tamper Proof Wrench for Cover of EPS
546-8000	Cover Tamper Switch for EPS Series